

KINETROL LTD. Model T-CRD Dashpot

SPECIFICATION

Rate	Adjustable See curves below ($\pm 10\%$)
Max. shaft side load	41 lbf / 183 N
Ambient temperature range	0° to 60°C
Frictional torque	0.5 lbf.in. / 0.056 Nm typical
Shaft material	High tensile steel 605M36(T)
Body material	Cast aluminum LM 4M
Weight	5.27 lbs/ 2.39 kg

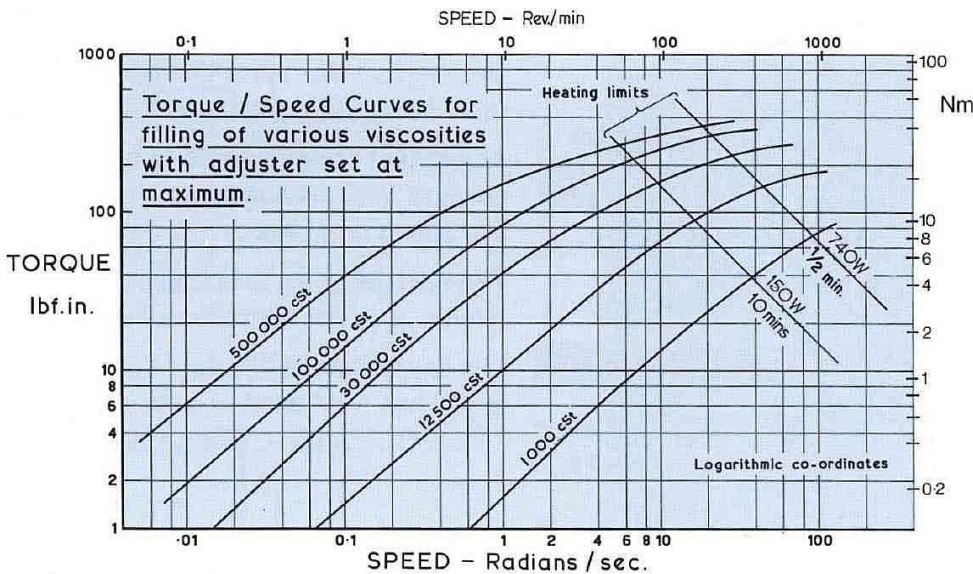
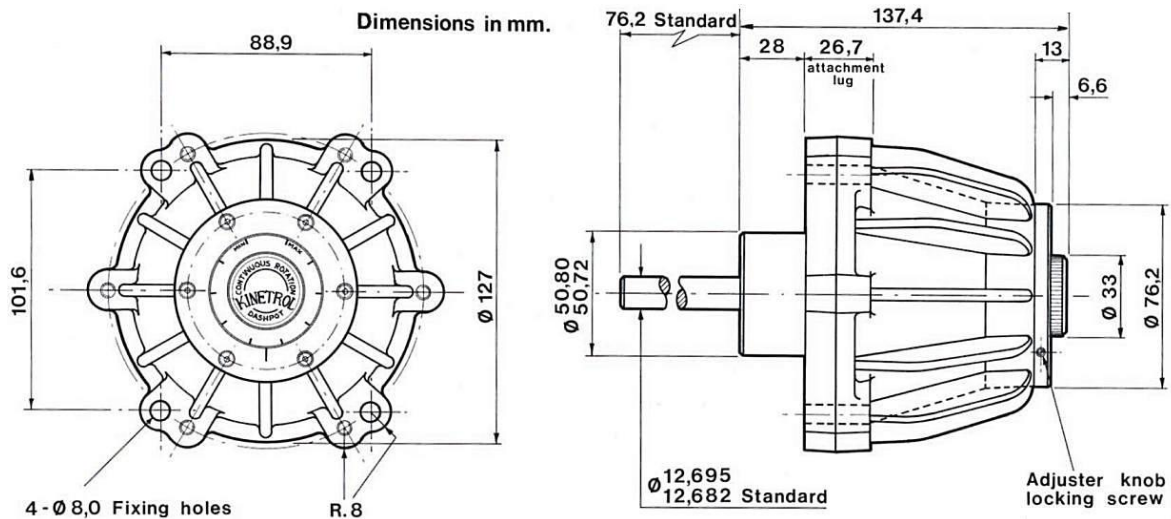

The T-CRD continuous rotation dashpot has an adjustable rate. Specification of a given silicone fluid filling provides maximum rates as shown by the curves opposite.

Adjustment allows the rate to be varied down to 1/10 of the maximum values, for any speed of rotation.

The adjuster knob, although marked for reference, is not normally calibrated.

VISCOSITIES AVAILABLE

1,000; 12,500; 30,000; 100,000; 500,000 cSt

ORDERING CODES

T-CRD-(Filling Viscosity)
Example: T-CRD-30,000 has 30,000 cSt fluid

Kinetrol LTD. Rotary dashpots distributed through:

Efdyn, Incorporated
7734 East 11th Street
Tulsa, Oklahoma 74112

www.efdyn.com

Toll Free: 800-950-1172
Phone: 918-838-1170
sales@efdyn.com

KINETROL LTD.

Model T-CRD Dashpot

TEMPERATURE EFFECTS

Damping rate is reduced by increases in fluid temperature (and increased by reduction in temperature). The graph below indicates the percentage change in damping rate with temperature, relative to the rate quoted at 20°C.

Dashpots compensated for temperature change, to keep damping rate constant, can be special ordered.

In addition to the effect of ambient temperature, heating of the dashpot above ambient is caused by the power absorbed by the damping action. Power dissipation limits are given for 20°C ambient. At temperatures above 20°C these power limits are de-rated by a factor:

$$\frac{(T_L - T_A)}{(T_L - 20)}$$

where T_L = Limit Temperature and T_A = Ambient Temperature

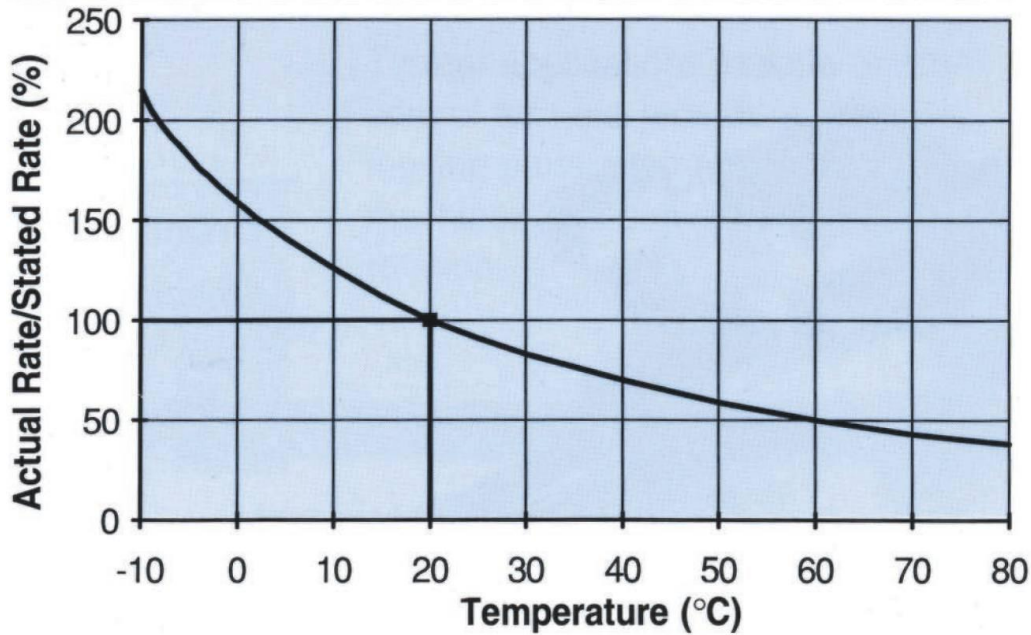

CONVERSION FACTORS

1 rad = 57.3°
1 Nm = 8.85 lbf.ins

1 RPM = 0.1047 rad/s
1 lbf = 4.45 N

1 lbf.ins = 0.113 Nm
9.81N = 1 kgf = 1 kp

GENERAL NOTES

1. For calculation purposes the rotation speed of the dashpot is given in RADIANS per second (1 radian = 57.3°). The significance of a radian is that if, for example, a 1 meter radius lever rotates through 1 radian, the end of the lever moves 1 meter, a distance equal to the radius.
2. Damping RATE is defined here as TORQUE divided by ROTATION SPEED. Note that a dashpot with a high rate may not necessarily be working at a high torque. For example, a dashpot may have a rate of 100 Nm/rad/s; however, it may be rotated at 1/10 rad/s so that the damping torque produced is 10 Nm which is not numerically equal to the rate.

Kinetrol LTD. Rotary dashpots distributed through: